



GAS COOLER

TEC-1624



TEP-1612



TEC-1612



TEC-1612
TEP-1612
TEC-1624

Operator's Manual

204 Technology Park Lane
Fuquay-Varina, NC 27526 USA
(919) 557-7300
www.apexinst.com

Rev. 9.22.2023



204 Technology Park Lane
Fuquay-Varina, NC 27526
www.apexinst.com
(919) 557-7300

For Support or Service Contact:

Technical Services Group
support@apexinst.com
(877) 726-3919

Disclaimer

Apex Instruments Inc. makes no representations or warranties with respect to this manual and, to the maximum extent permitted by law, expressly limits its liability for breach of any warranty that may be implied to the replacement of this manual with another. Furthermore, Apex Instruments reserves the right to revise this publication at any time without incurring an obligation to notify any person of the revision.

The information provided in this documentation contains general descriptions and/or technical characteristics of the performance of the products contained herein. This documentation is not intended as a substitute for and is not to be used for determining suitability or reliability of these products for specific user applications. It is the duty of any such user or integrator to perform the appropriate and complete risk analysis, evaluation and testing of the products with respect to the relevant specific application or use thereof. Neither Apex Instruments nor any of its affiliates or subsidiaries shall be responsible or liable for misuse of the information that is contained herein. If you have any suggestions for improvements or amendments or have found errors in this publication, please notify us.

All pertinent state, regional, and local safety regulations must be observed when installing and using this product. For reasons of safety and to help ensure compliance with documented system data, only the manufacturer shall perform repairs to components.

Failure to observe this information can result in injury or equipment damage.

Copyright © 2023 by Apex Instruments, Inc.

All rights reserved. No part of this publication may be reproduced, distributed, or transmitted in any form or by any means, including photocopying, recording, or other electronic or mechanical methods, without the prior written permission of the publisher.

Warranty Policy

Product Limited Warranty Policy

Apex Instruments, Inc. warrants products to be free from defects in materials and workmanship for a period of one year from date of delivery. During the warranty period, we will repair or replace, at our option, any component that fails due to a defect in materials or workmanship under normal use excluding installation. Items not manufactured by Apex Instruments are subject to original manufacturer's warranty. All returns must be shipped freight prepaid at the purchaser's expense.

Repair Services Limited Warranty Policy

Apex Instruments, Inc. warrants repairs to be free from defects in materials for a period of one year and workmanship for a period of 90 days from date of delivery. During the warranty period, we will repair any item Apex Instruments repaired or replaced that fails due to a defect in materials or workmanship under normal use.

What is Not Covered

Accidents, misuse, abuse and modifications. All forms of corrosion or other environmental conditions including lightning, natural disasters, improper installation and installation of an incorrect part. Normal wear and tear, used or salvage parts installed and shipping damage.

Contamination

Customer is responsible for decontamination of all equipment returned to Apex Instruments. Apex Instruments reserves the right to return or decontaminate any equipment deemed unsafe or contaminated at the customer's expense.

Additional Important Information

This limited warranty does not cover labor cost or incidental, indirect, special or consequential damages such as, but not limited to, physical injuries or property damage, loss of time, loss of use of the component, inconvenience, rental equipment charges, or accommodations resulting from a defect in or failure of the component. You must be the original purchaser of the component, warranty is not transferable.

This limited warranty represents the exclusive remedy for any component defect or failure and the total liability of Apex Instruments for any component it warrants.

Apex Instruments makes no other warranties, express or implied, including any warranties of merchantability, condition of any kind or fitness for a particular purpose.

Some states do not allow disclaimers of implied warranties. Therefore, all implied warranties that may apply to the component are limited to the duration of this written warranty. Some states also do not allow limitations on how long an implied warranty lasts or the exclusion or limitation of incidental, special or consequential damages, so the above information may not apply. This warranty provides specific rights and other rights which may vary from state to state. Apex Instruments, Inc. does not authorize any entity to vary the terms, conditions or exclusions of this warranty. If any provision of the warranty should become invalid or unenforceable because of any laws, the remaining terms and provisions of the warranty shall remain in full force and effect. To the extent allowed under local law, the remedies provided in this Limited Warranty Policy are the purchaser's sole and exclusive remedies. Apex Instruments, Inc., 204 Technology Park Lane, Fuquay-Varina, NC 27526. Visit us on the web at www.apexinst.com.

Acceptance of Terms and Conditions

Apex Instruments manufactures and sells its products under the foregoing terms and conditions and will not be bound to terms and conditions stated by any purchaser in any offer, acceptance or other contractual document. Placing an order or accepting delivery of products constitutes acceptance of terms and conditions.

Table of Contents

| | |
|---|-----------|
| Disclaimer..... | 3 |
| Retaining Instructions..... | 3 |
| Warranty Policy..... | 4 |
| 1.0 Preface..... | 9 |
| 1.1 Product Introduction..... | 9 |
| 1.2 Purpose of this Manual..... | 9 |
| 1.2.1 Relevant US EPA method descriptions..... | 9 |
| 1.3 Safety Instructions..... | 10 |
| 1.3.1 Safety information related to intended use..... | 10 |
| 1.3.2 Explanation of safety warnings..... | 10 |
| 1.3.3 Electrical shock..... | 10 |
| 1.3.4 Weight..... | 11 |
| 1.3.5 Elevated surfaces..... | 11 |
| 1.4 What To Do When the Unit Arrives..... | 11 |
| 1.4.1 Unpack and inspect..... | 11 |
| 1.4.2 Become familiar with console operations..... | 11 |
| 1.4.3 Leak checks..... | 12 |
| 1.5 How To Transport and Store the Unit..... | 13 |
| 1.5.1 Dimensions..... | 13 |
| 1.5.2 Lifting and handling..... | 13 |
| 1.5.3 Storage..... | 13 |
| 1.5.4 Shipping..... | 13 |
| 2.0 Description of the Product..... | 14 |
| 2.1 Gas Cooler..... | 14 |
| 2.2 Technical Specifications..... | 15 |
| 2.3 Main External Components..... | 16 |
| 3.0 Unit Operation..... | 17 |
| 3.1 User Control Overview..... | 17 |
| 3.1.1 Home screen overview..... | 17 |
| 3.1.2 Membrane switch pad buttons..... | 17 |

| | |
|--|-----------|
| 3.2 Pre-Field Test Operations..... | 18 |
| 3.2.1 Unit configuration..... | 18 |
| 3.2.2 Moisture Determination..... | 18 |
| 3.2.3 Preparation of sampling train..... | 18 |
| 3.2.4 Unit leak check procedure..... | 18 |
| 3.3 Field Test Operations..... | 18 |
| 3.4 Post-Test Field Operations..... | 18 |
| 3.5 Setting the Membrane Switch..... | 19 |
| 3.5.1 Set value setting..... | 19 |
| 3.5.2 Adjusting the Display Reading..... | 19 |
| 3.6 Operation Using Software..... | 20 |
| 4.0 Maintenance..... | 20 |
| 4.1 Pre-Test Calibrations..... | 20 |
| 4.1.2 Initial end user calibration checks..... | 20 |
| 4.2 Post-Test Calibrations..... | 20 |
| 4.2.2 Temperature sensors..... | 20 |
| 4.3 Post-Test Maintenance..... | 21 |
| 4.3.1 Purging..... | 21 |
| 4.3.2 Cleaning..... | 21 |
| 4.3.3 Inspections..... | 21 |
| 4.4 Semi-Annual Maintenance..... | 21 |
| 4.5 Annual Maintenance..... | 21 |
| 4.6 Manufacturer support for the product..... | 23 |
| 4.6.1 Technical services..... | 23 |
| 4.6.2 Calibration services..... | 23 |
| 4.6.3 Obtaining documentation and information..... | 23 |
| 5.0 Troubleshooting..... | 24 |
| 5.1 LCD Screen..... | 24 |
| 5.1.1 No power to LCD screen..... | 24 |
| 5.1.2 Screen contrast too dim or bright, cannot read characters on screen..... | 24 |
| 5.3 Temperatures..... | 24 |
| 5.3.1 TC displayed values are changing too quickly to read..... | 24 |
| 5.3.2 TCs reading inaccurately..... | 24 |
| 5.4 Additional Common Console Problems..... | 24 |
| 6.0 TEP-1612 Fuji Temperature Controllers..... | 25 |
| 6.1 Settings..... | 25 |
| 6.1.1 Set Value (SV) Setting..... | 25 |
| 6.1.2 Thermocouple Type Setting..... | 25 |
| 7.0 Diagrams and Schematics..... | 26 |
| 7.1 TEC-1612 Electrical Diagram..... | 26 |
| 7.2 TEP-1612 Electrical Diagram..... | 27 |
| 7.3 TEC-1624 Electrical Diagram..... | 28 |
| 7.4 TEC-1612 Plumbing Diagram..... | 29 |
| 7.5 TEP-1612 Plumbing Diagram..... | 30 |
| 7.6 TEP-1624 Plumbing Diagram..... | 31 |

Reserved

Figures

| | |
|---|----|
| Fig. 1 Example Sampling System..... | 14 |
| Fig. 2 TEC-1612, TEP-1612 and TEC-1624 Dimensions..... | 15 |
| Fig. 3 TEC-1612/TEC-1624 Main External Components..... | 16 |
| Fig. 4 TEP-1612 Main External Components..... | 16 |
| Fig. 5 Minimum Free Space..... | 17 |
| Fig. 6 User Interface..... | 17 |
| Fig. 7 Temperature Controller Configuration..... | 19 |
| Fig. 8 Adjust Temperature Display Reading..... | 19 |
| Fig. 9 SC-1612 Disassembly and Reassembly..... | 22 |
| Fig. 10 Temperature Controller Configuration..... | 25 |
| Fig. 11 TEC-1612 Electrical Diagram..... | 26 |
| Fig. 12 TEP-1612 Electrical Diagram..... | 27 |
| Fig. 13 TEC-1624 Electrical Diagram..... | 28 |
| Fig. 14 TEC-1612 Plumbing Diagram..... | 29 |
| Fig. 15 TEP-1612 Plumbing Diagram..... | 30 |
| Fig. 16 TEC-1624 Plumbing Diagram..... | 31 |

1 Preface

1.1 Product Introduction

Congratulations on your purchase of an Apex Instruments TEC-1612/TEP-1612/TEC-1624 Thermoelectric Gas Cooler! These units are robust, single-stage gas coolers that effectively remove condensate from the sample gas and delivering dry gas to the analyzer. The TEC-1612 is designed to be mounted on a wall or in a rack. The TEP-1612 portable model is designed to be used as a stand-alone unit or coupled with our ACC-1610 Air-Cooled Condenser.

1.2 Purpose of this manual

The purpose of this manual is to provide a basic understanding of the Apex Instruments TEC-1612, TEP-1612 and TEC1624 Gas Coolers. The units are applicable for use with a variety of US EPA sampling methods and Apex Instruments consoles.

Additionally, this manual provides the users with a reasonable amount of reference information on system configuration, calibration procedures, maintenance and troubleshooting as it applies to the specific product and the US EPA Regulations.

1.2.1 Relevant US EPA method descriptions

Method 5 - Determination of Particulate Matter Emissions From Stationary Sources

Method 17 - Determination of Particulate Matter Emissions From Stationary Sources

Method 23 - Determination of Polychlorinated Dibenzo-p-Dioxins and Polychlorinated Dibenzofurans From Stationary Sources

Method 26A - Determination of Hydrogen Halide and Halogen Emissions from Stationary Sources

Method 29 - Determination of Metals Emissions from Stationary Sources

Method 201A - Determination of Pm10 and PM2.5 Emissions from Stationary Sources

Method 202 - Dry Impinger Method for Determining Condensable Particulate Emissions from Stationary Sources

Detailed information on method sampling may be found through the US EPA website - please visit <https://www.epa.gov/emc/emc-promulgated-test-methods> for complete method descriptions

1.3 Safety Instructions

1.3.1 Safety information related to the intended use

Source sampling is intended to be performed by technicians who have been trained in source sampling methods. Personnel conducting source sampling are expected to understand basic gas laws and chemistry.

In addition, all technicians should have adequate general safety training to identify, abate and prevent job-related hazards including site-specific training.

Please visit the following link for more information on Source Sampling Safety Procedures and Protocols:
<http://www.sesnews.org/>

1.3.2 Explanation of safety warnings



“DANGER” indicates a hazard with high level of risk which, if not avoided, will result in death or serious injury.



“WARNING” indicates a hazard with medium level of risk which, if not avoided, could result in death or serious injury.



“CAUTION” indicates a hazard with low level of risk which, if not avoided, could result in minor or moderate injury.



“NOTICE” Indicates information considered important, but not hazard-related.

1.3.3 Electrical shock



Use and maintenance of the cooler presents potential electrical hazards.

Ensure the unit is protected from wet conditions such as rain or process emissions. If wet, cease operations until it has been adequately dried.

Do not perform maintenance when plugged into a power source and the main power switch is turned on.

Do not continue to use if wires are exposed or loose from their connectors.

1.3 Safety Instructions cont.

1.3.4 Weight



Although the unit is compact and lighter than previous versions, the unit itself can present risks due to its weight. When carrying the unit, make sure to use proper form to lift using your legs. Lift and carry the unit using the provided handles or by holding the entire unit close to the body. If a user is not comfortable carrying the unit, a partner may provide the necessary assistance in moving the unit around.

1.3.5 Elevated surfaces



Use of the unit on elevated surfaces also poses risks that range from minor to fatal. Be sure to operate the unit on a level, stationary surface. If necessary, secure the unit using straps or braces to ensure that vibration or accidental contact does not knock the unit off of its surface.

1.4 What To Do When the Unit Arrives

1.4.1 Unpack and inspect

Unpack the unit from its shipping container. Inspect the exterior of the unit for visible damage or missing components. Remove the lid by using the four butterfly latches and visually inspect the front of the unit.



Do not tamper with the internal components unless otherwise recommended.

Check the packing list to ensure that everything has arrived.
A power cord will also be included for any units that use 120V supplied power.

1.4.2 Become familiar with console operations

Perform mock sample runs to ensure operation of console follows proposed test plan and EPA Method procedures.

1.4.3 Leak checks

Perform the console leak checks as explained in *Section 3.2.5 Console leak check procedure*.

1.4.4 Calibration Checks

The unit is sold with a factory calibration on the sensors and thermocouples provided with the unit. Apex Instruments suggests performing calibration checks of the sensors before and thermocouples after each testing period and performing a full calibration on the sensors and thermocouples annually. Ensure that you verify calibration standards with your local administrator.

Perform the unit calibration checks as explained in *Section 4.1 Pre-Test Calibrations*.

1.4.5 Test plan and methods

Begin the sampling operation procedures as directed by the applicable EPA Method and local compliance regulations.

1.5 How To Transport and Store the Unit

1.5.1 Dimensions

See 2.4 *Technical Specifications*

1.5.2 TEP-1612 Lifting and handling



Avoid dropping the unit and other forms of collision during transport. When lifting, make sure to use the handle to lift. Do not try to lift the unit by anything other than the handle.

1.5.3 TEP-1612 Storage

Store upright, if possible, in a controlled environment on a shelf off of the ground. The unit should be stored in the case with the Front Cover attached and disconnected from power.

1.5.4 Shipping

While the unit features a rugged design, the components and integrity of the build are delicate; the unit should be treated as a lab instrument when considering transport. Sudden jarring movements or drops could damage the internal components or cause faults within the electrical subsystem and various sensors.

The unit should not be shipped independently. Ensure proper shipment of the unit by packing it in a foam-lined box or an appropriate shipping container that provides adequate protection.

2.0 Description of the Product

2.1 Gas Conditioners

The Apex Instruments TEP-1612, TEC-1612 and TEC-1624 Thermoelectric Gas Coolers are robust single-stage gas cooling systems that remove condensate and deliver dry gas to the analyzer. The TEP-1612 is designed to be portable and used as a stand-alone unit or coupled with our ACC-1610 Air-Cooled Condenser. The TEC-1612 and TEC-1624 are designed to be mounted on a wall or in a rack.

The gas coolers contain easily removable 316 stainless steel condensers which can be treated with a variety of coatings: silicon, polyfluorinated, silane: polar or non-polar. The micro annular flow channel provides maximum condensation efficiency with minimum contact time. The single condenser setup improves response time in the TEP-1612 and TEC-1612.

The condensers are encased in an insulated aluminum block and cooled by two state-of-the-art Thermoelectric heat pumps. Dual high output axial fans are coupled with the latest thermosiphon heat exchangers to support the thermoelectric units and allow the gas cooler to operate in a wider range of ambient conditions.

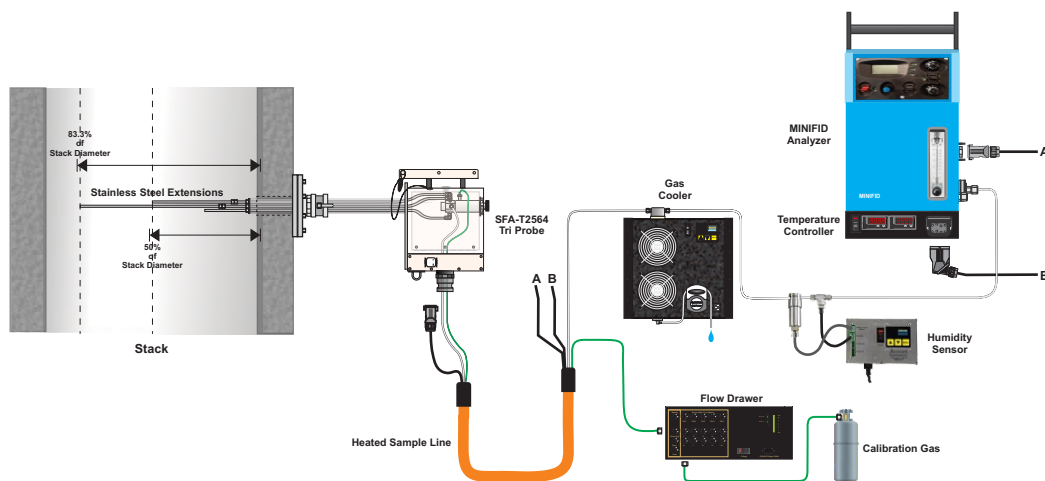

Fig. 1 TEC-1612. Example Sampling System: Ancillary components of the sampling system are sold separately.

2.2 Technical Specifications

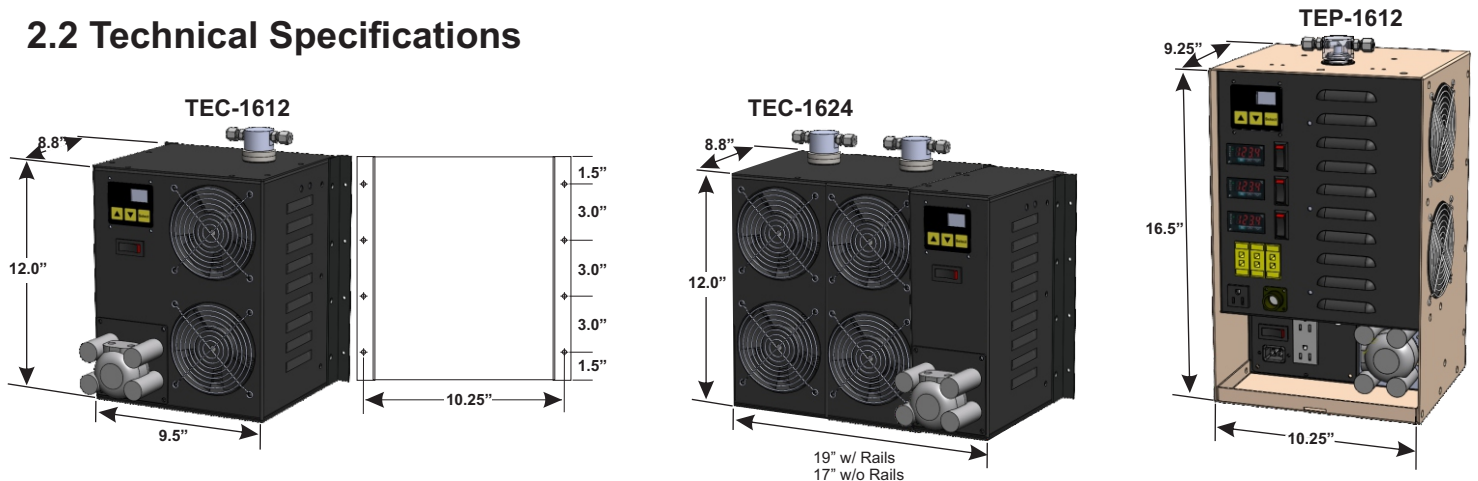

Fig. 2 TEC-1612, TEC-1624 and TEP-1612 Dimensions

- Refrigeration: Pinnacle Heat Pump System: two 80-watt solid-state thermoelectric modules
- Power Supply: 120-240 VAC 10-15Amps 120V@15A 240V@10A
- Temperature display: OLED display +/- 0.1 °C/°F
- Temperature control: variable DC voltage controller, 3-button keypad
- Auxiliary temperature controllers: digital temperature controllers for probe, oven, and heated jumper; type-K thermocouple input
- Ambient operating temperature: 32 to 104 °F (0 to 40 °C)
- Cooling capacity: 200 BTU per hour
- Cold block: insulated aluminum
- Radiator: two low-profile heat sinks with six 6-mm diameter U-tube heatpipes, coated fins for corrosion resistance, 120-mm 106 cfm axial fans, with encapsulated motor and electronics
- Condenser: stainless steel, reverse flow condensate separator: alloy 316 stainless steel, various Coatings available, 1" OD x 12"
- Condensate removal: integrated peristaltic pump, 10 ml/min
- Lines: 1/4" diameter
- Dimensions:

| | |
|-----------|--|
| TEC-1612- | 9.5" W x 12.0" H x 8.8" D (241mm W x 305mm H x 224mm D) |
| TEC-1624- | 19.0" W x 12.0" H x 8.8" D (483mm W x 304mm H x 224mm D) |
| TEP-1612- | 10.25" W x 16.5" H x 9.25" D (260mm W x 419mm H x 235mm D) |
- Weight:

| | |
|----------|--------------------|
| TEC-1612 | 26.0 lbs (11.8 kg) |
| TEP-1612 | 30.7 lbs (13.9 kg) |
| TEC-1624 | 39.7 lbs (18.0 kg) |

2.3 Main External Components

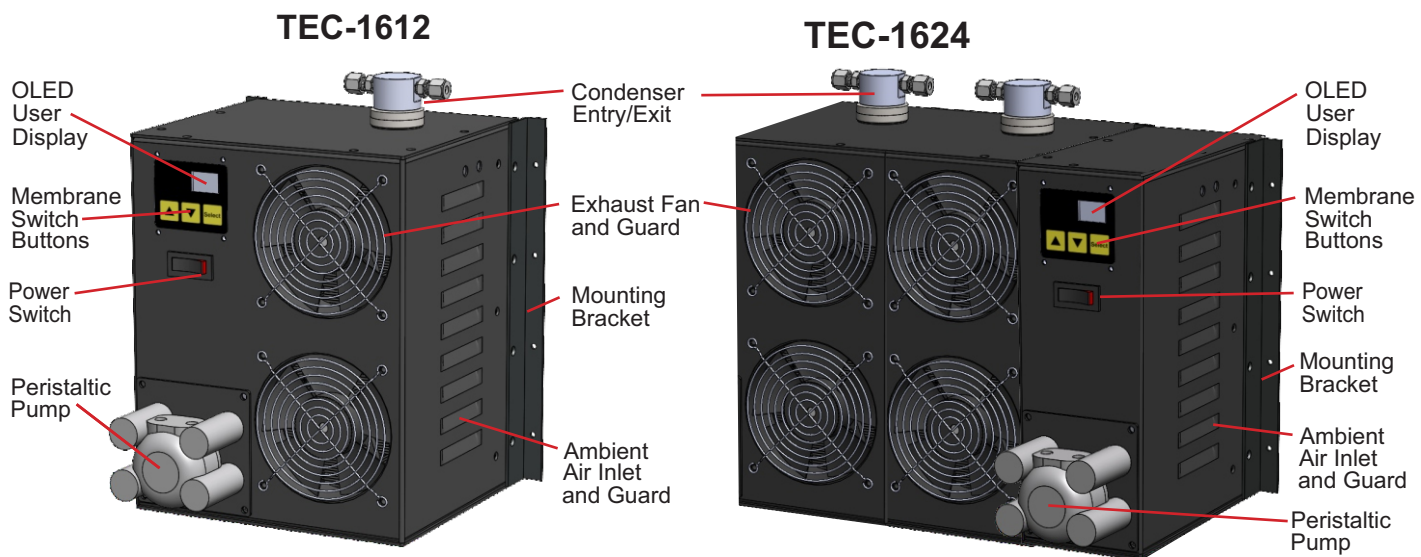

Fig. 3 TEC-1612 and TEC-1624
 Front, Rear and Bottom Panel Overview: Standard version shown, depiction of options may differ.

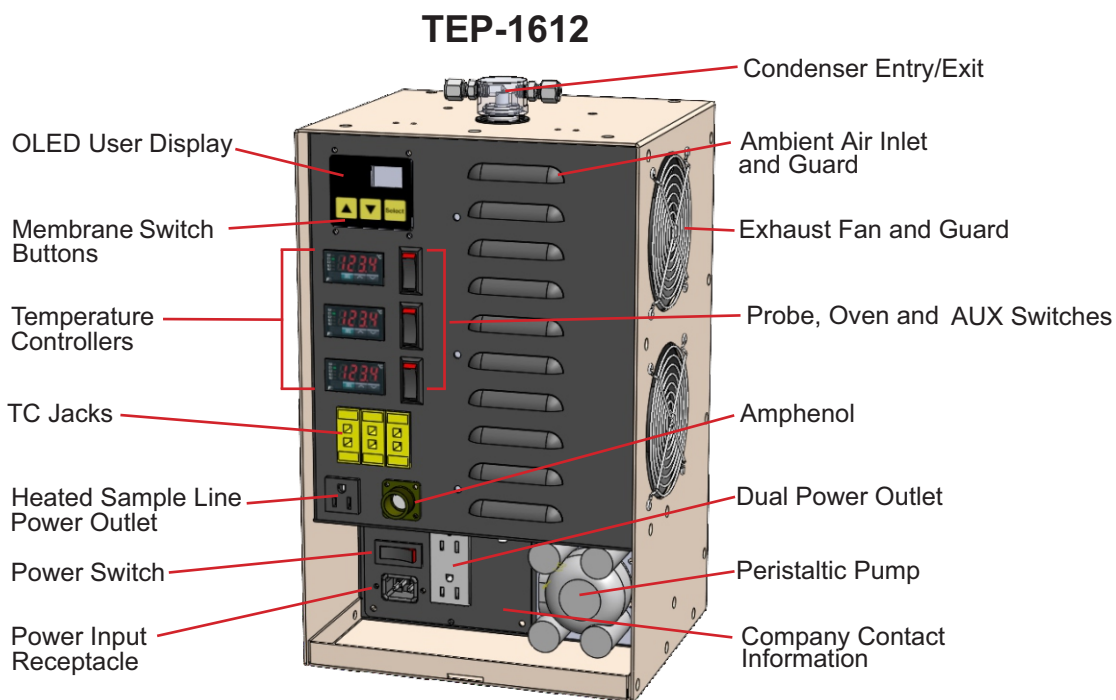

Fig. 4 TEP-1612. Front, Rear and Bottom Panel Overview: Standard version shown, depiction of options may differ.

3.0 Unit Operation

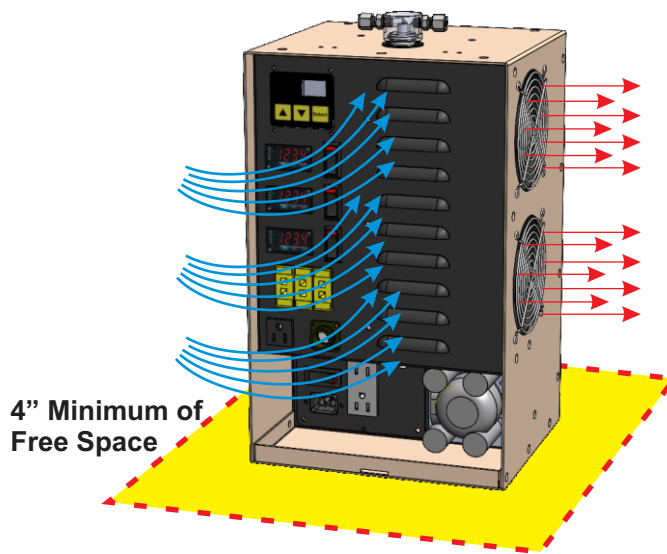

Fig. 5 Minimum Free Space

NOTICE

Allow a minimum of 4 inches (10cm) of free space around unit to allow for proper air flow into and out of vents.

3.1 User Control Overview

3.1.1 Home screen overview

The home screen on the coolers allows the operator to view the set point and current block temperature in selectable units, °C or °F.

Set Point: The current set point is displayed in yellow text. The set point can be adjusted on the fly and the units can be changed between °C and °F.

Block Temperature: The current block temperature is displayed in blue text. The units of this value can be changed between °C and °F.

NOTE: See Section 5.3 for Temperature Offset

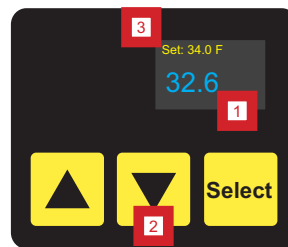





Fig. 6 User Interface

3.1.2 Membrane switch pad buttons

| | |
|---|--|
|  | - Press and hold for 3 seconds to change the set point and displayed units between °C and °F |
|  | - Press once to increase the set point by 0.1 °C or 0.1 °F |
|  | - Press once to decrease the set point by 0.1 °C or 0.1 °F |

3.2 Pre-Field Test Operations

3.2.1 Unit configuration

Ensure that the following unit settings are configured in the lab before performing a field test: unit types and chiller block set point.

To change the unit types between °C and °F, press and hold the Select button for 3 seconds. To adjust the set point, press the Up or Down buttons until the desired set point is displayed in yellow.

3.2.2 Moisture determination (if applicable)

At the sampling location, prior to testing, determine the percent moisture of the stack gas using the wet and dry bulb temperatures or, if appropriate, a relative humidity meter. Another option is a moisture approximation through procedures outline in EPA Method 4.

3.2.3 Preparation of sampling train

Assemble the sampling train as shown in the applicable EPA Method. Adjust the probe and oven/filter, heaters, as applicable, to a temperature warm enough to prevent water condensation or as dictated in the sampling method using the respective temperature controllers on the test console; keep in mind the previously determined moisture content of the gas stream.

Turn on the thermoelectric cooler and set the desired set point. Allow for adequate cooling time before beginning sampling.

Refer to *Sections 3.1 and 3.5* of this manual for instructions on how to operate the unit's membrane switch temperature controller.

3.2.4 Unit leak check procedure (reserved)

At the sampling location, prior to testing, perform a leak check of the unit while installed in the sample train. As the unit does not have a sample gas pump or a flow rate meter, the unit is best leak checked with the entire system. Refer to the operator's manual of the test console to understand the sample train leak check procedure.

3.3 Field Test Operations (reserved)

The gas cooler operation is fairly straightforward, therefore follow the operations as described in the operator's manual for the test console.

3.4 Post-Field Test Operations (reserved)

The gas cooler does not currently require post-test checks in the field. Refer to the test console's operator's manual for any other checks that are required by the applicable test method.

3.5 Setting the Membrane Switch Temperature Controller

3.5.1 Set value setting

1. The current temperature of the equipment is shown in blue on the OLED display.
2. The units can be changed if the Select button is held down for three seconds to toggle between °F and °C.
3. To change the set value (SV), press the Up or Down buttons until the desired temperature displayed in yellow is reached. The unit will then adjust to meet the set value.

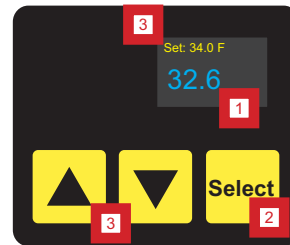

Fig. 7 Temperature Controller Configuration

NOTE: See section 6.0 for TEP-1612 Fuji Temperature Controllers

3.5.2 Adjusting the temperature display reading

1. Hold the Select button for approximately 6 seconds to enter the display offset menu.
2. Remove the temperature sensor and place it in an ice bath accompanied by a calibrated, NIST-traceable thermometer.
3. To change the displayed value, press the Up or Down buttons until the desired temperature displayed in yellow is reached. This should match what the reference thermometer is displaying.

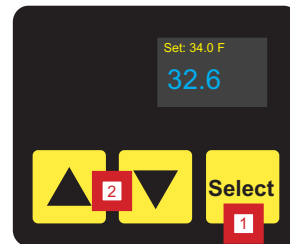

Fig. 8 Adjust Temperature Display Reading

3.6 Operation using software (reserved)

The TEC-1612, TEC-1624 and TEP-1612 do not currently use software for operation, all functions are controlled on the unit itself.

4.0 Maintenance

4.1 Pre-Test Calibrations

4.1.1 Factory calibration

Apex Instruments performs an initial calibration on the temperature sensor against a NIST-traceable thermometer.

4.1.2 Initial end user Calibration Checks

Although the unit's temperature sensor is factory calibrated, Apex Instruments suggests that the end user check the calibration of the thermocouples by taking the TC out of the chiller block and dipping it in an ice bath that also has a calibrated thermometer dipped inside. Ensure the temperature sensor display reading matches the calibrated thermometer at or near freezing, 32 °F (0 °C). If it does not, adjust the unit reading to match the ice bath's thermometer using the offset function detailed in Section 3.5.2. Adjusting the temperature display reading on page 19 of this manual.

4.2 Post-Test Calibrations

4.2.1 Temperature sensors

Perform a calibration check on the Temperature Reading. An alternative thermometer, such as a NIST-traceable digital thermometer, may be used if the thermometer is, at a minimum, equivalent in terms of performance or suitably effective for the specific temperature measurement application.

4.3 Post-Test Maintenance

4.3.1 Purging

At the conclusion of a test series, it is highly recommended to “purge” the unit plumbing by drawing in clean, ambient air for 10 minutes or greater. This process will extend the life of the internal tubing, fittings and other parts that contact sample gas. The purge can be conducted by turning the test console’s sample pump on and opening the valves to draw air through the inlets of the cooler while still connected to the console.

4.3.2 Cleaning

Maintaining the cleanliness of the unit will also extend the life of its components. The outside of the case, if applicable, and console can be cleaned with a non-abrasive, weak degreaser or soapy water. Ensure that exposed electrical components are not sprayed during this process. Dust and other particulate should also be removed from the inside of the unit by using a vacuum or compressed air.



Never clean the unit while it is connected to power or in a wet location.

Condenser Maintenance

1. Remove the elbow at the bottom of the condenser assembly and set aside after cleaning off old tape.
2. Remove the condenser assembly from the cooler block.
3. Wipe the heat sink grease from the outer condenser tube. Unscrew the inner condenser tube from the cap. Pull the cap from the outer inlet/outlet tube.
4. Remove the o-ring seals from the cap and inner condenser tube with a pick or similar tool. Clean all of the parts with a mild soap in warm water. Dry thoroughly.
5. Install the o-ring seals for the cap and inner condenser tube. Lubricate o-rings with a thin layer of vacuum grease prior to installation in steps 6 and 8.

A blue rectangular icon with a white border. The word "NOTICE" is written in white, bold, uppercase letters.

The outer condenser tube is chamfered. Make sure this end is inserted into the cap.

6. Lube cap o-ring with vacuum grease. Insert the cap onto the chamfered end of the outer condenser tube by applying even, downward pressure to the cap until it seats. Avoid twisting or pounding on the cap.
7. Lube inner condenser o-ring with vacuum grease. Insert the inner condenser tube into the outer condenser assembly.
8. Secure the cap. Screw the inner condenser tube into the cap by hand. Use the spanner adapter tool and torque wrench to apply 35 in-lbs. of torque to seat the inner condenser to the cap.

A blue rectangular icon with a white border. The word "NOTICE" is written in white, bold, uppercase letters.

DO NOT OVER TIGHTEN beyond 35 in-lbs. of torque.

9. Apply a thin layer of heat transfer grease to the entire length of the outer condenser tube and insert back into the cooler.
10. PTFE tape the elbow threads and install into the condenser assembly.
11. Leak check the assembly to ensure the assembly is sealed.

Fig. 9 SC-1612 DISASSEMBLY AND REASSEMBLY



4.3.3 Inspections



Periodically inspect components of the unit to ensure everything is in working order and nothing is exhibiting a sign of future issues. Check for things such as exposed or frayed wires, melted or damaged electrical components, discolored or cloudy tubing, and any sign of moisture. Any signs of damage to the internal or external components of the console should be replaced immediately.

4.4 Semi-Annual Maintenance

All components of the unit should be calibrated and evaluated on a semi-annual schedule (once a quarter or every six months). This comprehensive procedure should include calibration of the temperature sensors. Post-test calibrations and calibration checks satisfy this suggestion.

4.5 Annual Maintenance

Apex Instruments highly recommends that the unit be returned to Apex Instruments on an annual basis. The Technical Services Group will perform an evaluation of all components of the system including functionality and build-integrity checks. All sensors will be calibrated.

4.6 Manufacturer Support for the Product

4.6.1 Technical services

Our knowledgeable service staff includes skilled industry professionals, stack testers and technicians ready to help with specific service needs. From basic troubleshooting to full equipment overhauls and repairs, our technical service team can help.

Phone: (919) 346-5754, Toll Free (877) 726-3919

Email: support@apexinst.com

4.6.2 Calibration services

Apex Instruments does not require this unit to be sent to us for calibration services to meet warranty.

4.6.3 Obtaining documentation and information

Internet

Detailed product information, firmware and/or software, stack sampling guides and EPA regulation references are available on our website: <https://www.apexinst.com>

Support and service

Any requests for field data sheets, calibration spreadsheets, diagrams or component supporting documentation, please reach out to our Technical Services Group for assistance.

5.0 Troubleshooting

5.1 Power

5.1.1 No power to unit or screen



1. 5-Pin Connector in the center of the board is not secure or plugged into incorrect pins
Resolution - Ensure that all wires are firmly clamped inside of the connector and that the connector is plugged into the board
2. Unit main power switch is not turned on
Resolution - Turn on the main power switch
3. Unit is not plugged in to a working power outlet
Resolution - Find an appropriate power source with the correct voltage output and plug the power cord in to the outlet

5.2 Performance

5.2.1 Decreased cooling performance or unit not reaching set point

1. Heat sinks are dusty or clogged and/or restricted air flow through unit.
Resolution - While the unit is disconnected from power, use a vacuum or compressed air to remove the dust from the heat sinks. A soft brush may also be used to agitate build-up.
2. Foam around chiller block has degraded
Resolution - Replace the foam around the chiller block with a suitable density/material. Unit should be sent in for repair.
3. Restricted air flow through unit.
Resolution - Insure fans are operational and there is 4" of free space around unit to assure air flow. Remove any impediments to air flow. Check vents for blockage. Clean/remove blockage.

5.3 Temperature Offset

5.3.1 Temperature sensor reading inaccurately

1. Adjust temperature sensor offset
Resolution - Press and hold the "Select" button for 6 seconds to enter the temperature offset function. Compare the sensor reading to NIST-traceable device in ambient or ice bath conditions.

5.3.2 Temperature display showing "NO TC"

1. Replace temperature sensor/probe
Resolution - Order a new temperature probe and install it in place of the defective temperature probe. Audit the new temperature probe against a NIST-traceable reference device in ambient or ice bath conditions.

6.0 TEP-1612 Temperature Controller Settings

6.1 Settings

FUJI M-PRX3-# Temperature Controllers (NOTE: °F shown)

6.1.1 Set Value (SV) Setting



To change the Set Value (SV) press **SEL** once. Current Value is displayed and SV is lit.

Press the **↑** **↓** to increase or decrease the displayed SV.

After the new setting is entered press **SEL** to lock in the value and return to PV display.

Repeat procedure to check value if necessary.

6.1.2 Thermocouple Type Setting

The Thermocouple Type is a 2nd Block Parameter.

Press and hold **SEL** for about 3 seconds.

ProG will be momentarily be displayed then P will be displayed.

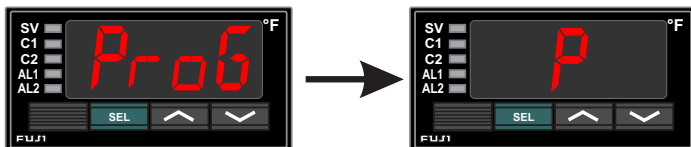

Press **↓** repeatedly until Pn-2 displayed.



Press **SEL** The current Thermocouple Type Code will be displayed.



Type K code is 3. If not 3 press **↑** **↓** to reach 3. The new value will flash.

Press **SEL** for about 2 seconds to lock in and return to SV display.

Press **SEL** to return to PV display. Repeat procedure to check value if necessary.

7.2 TEC-1612

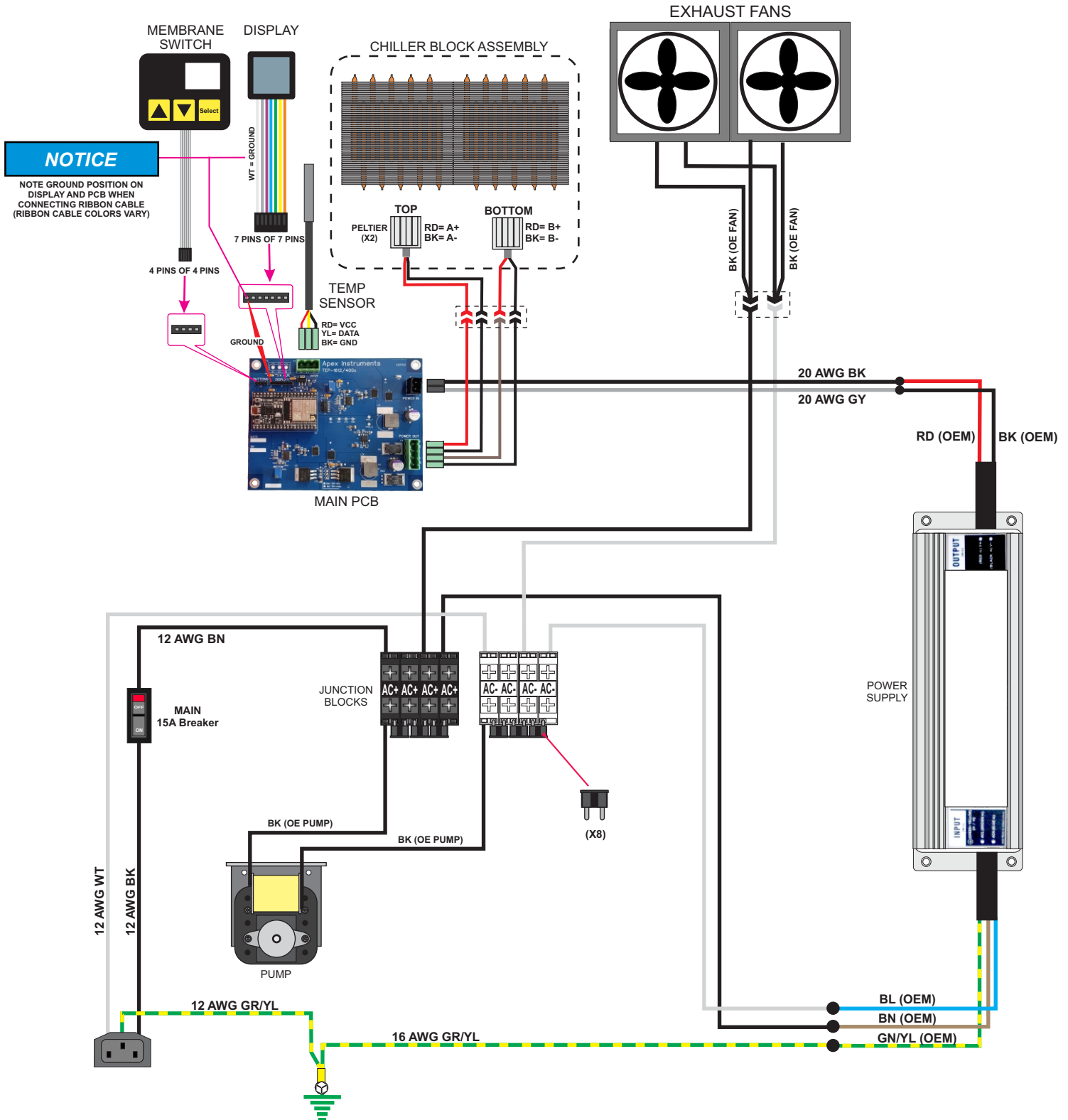

7.3 TEC-1624

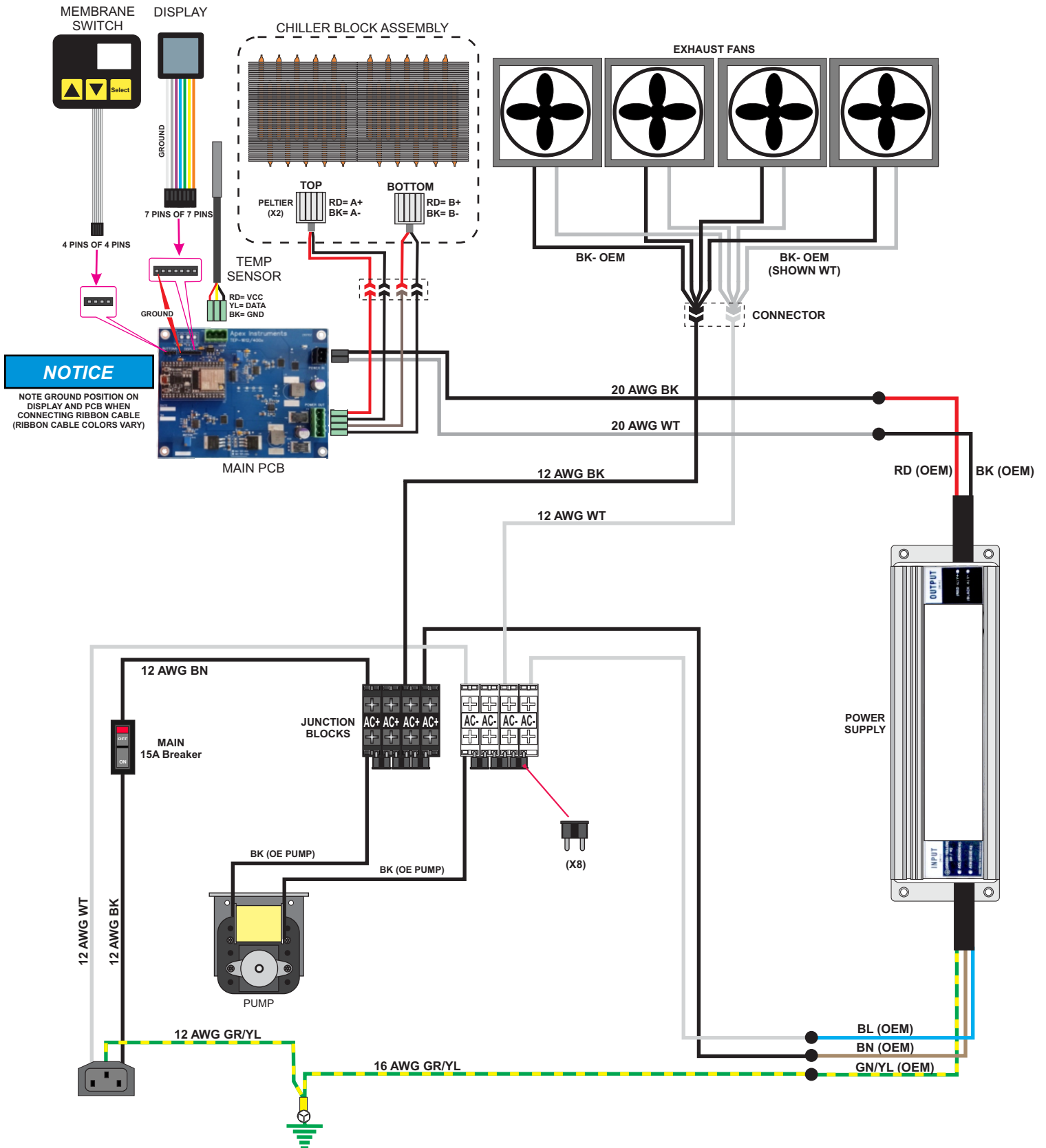

7.4 TEC-1612

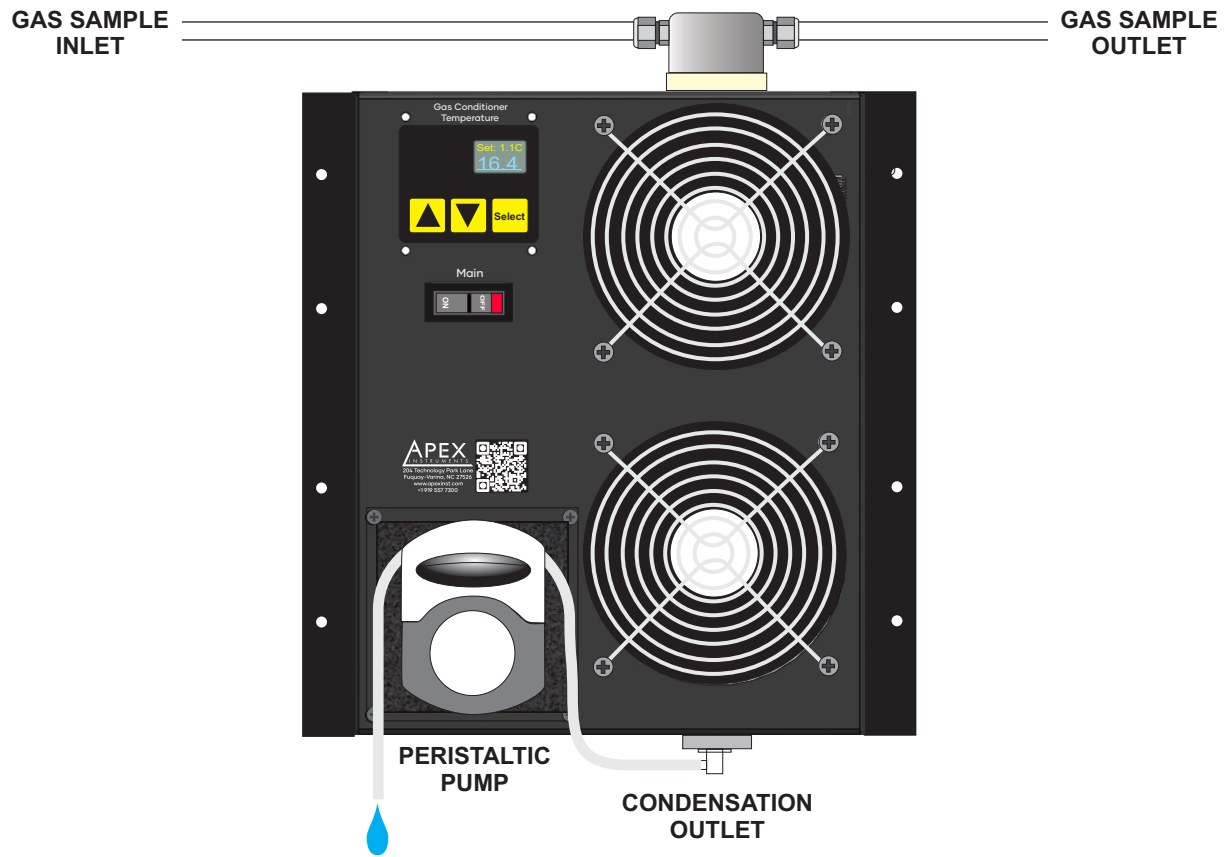

7.5 TEP-1612

GAS SAMPLE
INLET

GAS SAMPLE
OUTLET

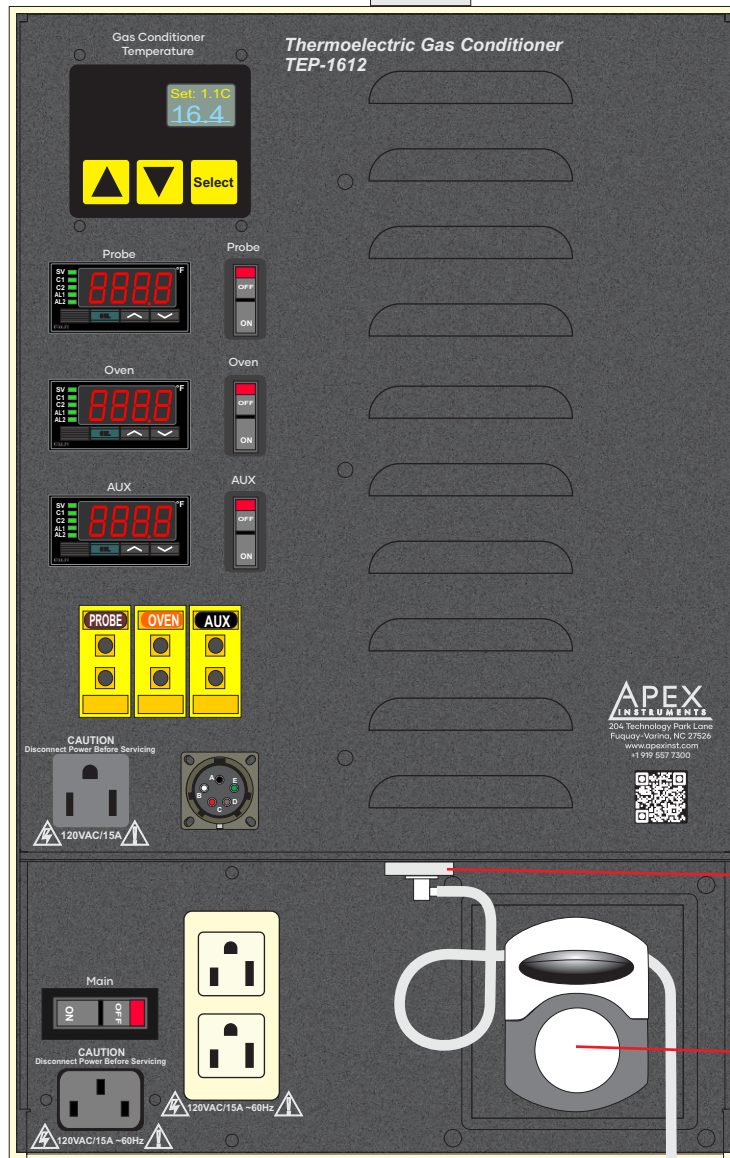

CONDENSATION
OUTLET

PERISTALTIC
PUMP

7.6 TEC-1624

