



WORLDWIDE LEADER OF SOURCE SAMPLING EQUIPMENT

▶ **AFD-510**

GAS DISTRIBUTION PANEL

FLOW CONTROL OF STACK AND CALIBRATION GASES

The **AFD-510 Gas Distribution Panel** is designed to be an easy, convenient, and compact way to control the flow of both stack and calibration gases.

The panel can flow gas to either the analyzer bank (direct calibrations) or the probe (system calibrations), and has both automatic and manual controls.

Designed with simplicity in mind, it has the same common solenoids and a simplified wiring protocol. The calibration gas in use is identified by a LED along with which mode you are in and if you are sampling or calibrating.



Model AFD-510

Easy, Convenient, Compact.

Features

- During sampling mode all solenoids are at "rest", greatly extending the life of the unit
- 11 calibration gas channels (including zero and span)
- 5 output or analyzer channels
- 8 valved rotometers for fine flow control and adjustment
 - 5 analyzer rotometers
 - 1 vent rotometer
 - 1 probe calibration
 - 1 sample flow rotometer
- 19-inch rack-mountable
- Designed for easy maintenance and repair
- Manual or automatic operation
- Panel can flow gas to either the analyzer bank (direct calibrations) or the probe (system calibrations)
- Has both automatic and manual controls

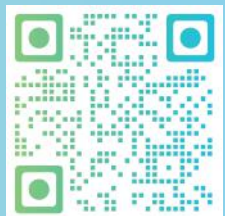

▶ AFD-510

GAS DISTRIBUTION PANEL FLOW CONTROL OF STACK AND CALIBRATION GASES



2

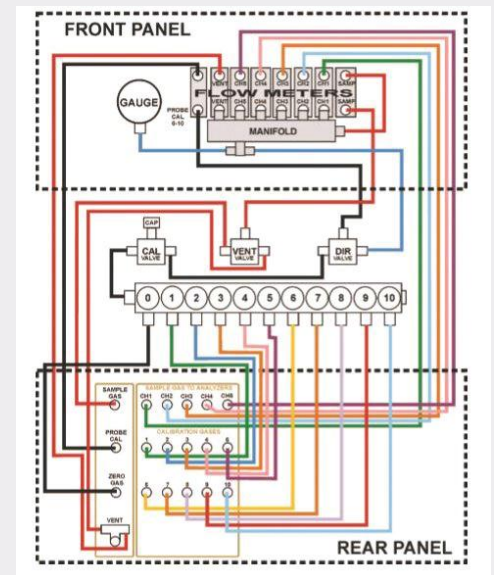

Specifications

Input cal-gas channels:

Flowmeter standard:

- Sample 0-10 LPM
- Vent 0-10 LPM

Output gas channels:

Flowmeter:

- 0.2-2.5 LPM

Voltage: 110.220 VAC at 50/60 Hz

Power: 25 Watts

Mounting dimensions: 4U, 19-inch rack-mount, 7-inch height x 19-inch width x 18-inch depth

Weight: approximately 24 lbs

Pressure gauge: 0-15 psi

Connections: 1/4 inch stainless steel tube union

